

Industrial PC IPC191I7

General
Operating, Maintenance and Installation
Manual

Hardware Platform Gateway



IPCOMM GmbH

Walter-Bouhon-Strasse 4
90427 Nuremberg

Germany

Phone: +49 911 18 07 91-0

Fax: +49 911 18 07 91-10

Internet: <http://www.ipcomm.de>

Email: info@ipcomm.de

Edition Mai 2017
Version 3.0



DIN EN ISO 9001:2008
Zertifikat: 01 100 040757

Table of Contents

- 1 Introduction 2
- 2 Hardware Description 3
 - 2.1 General 3
 - 2.2 Hardware Components 4
 - 2.2.1 Mainboard 4
 - 2.2.2 Onboard RS-232 Interfaces 5
 - 2.2.3 8-Port RS-232 Serial Interface Card (RS-232 interface for remote communication) 5
 - 2.2.4 Ethernet Interfaces 6
 - 2.2.5 CFAST Memory Card 6
 - 2.2.6 CMOS Lithium Battery 7
 - 2.2.7 CPU LED 7
 - 2.2.8 Power Supply 8
 - 2.2.8.1 AC Power Supply 8
 - 2.2.8.2 DC Power Supply 9
- 3 Overview of Variants / Interface Configuration 10
 - 3.1 Variant A 10
 - 3.2 Variant E4M 10
 - 3.3 Variant E4 11
 - 3.4 Variant E8 11
 - 3.5 Variant L 11
- 4 Technical Data 12
- 5 Nomenclature of IPC19117 Item Code 15
- 6 IPC191 CAD-Chart 16

1 Introduction

All technical information, descriptions and illustrations contained in this 'Operating, Maintenance and Installation Manual' remain our property and shall not be used otherwise than for operating this system, nor shall they be copied, reproduced or passed on to third parties or brought to their notice without our prior written consent.

The information represented in this manual is in keeping with current standards and is subject to later alterations.

This manual contains important instructions referring to safe installation, commissioning, operation and maintenance.

Read this manual carefully before starting up the gateway and observe the instructions.

In order to comply with the guidelines for electro-magnetic compatibility in industrial PCs (or other variants) only CE-certified components are used in compliance with project-specific requirements. Moreover, a maximum cable length of 30 meters shall be allowed.

All trademarks and brand names contained in this user manual are for identification purposes only and can be owned by their respective holders.

Finally we want to draw your attention to the fact that any warranties with respect to the industrial PC will be invalid in the event that:

- Operation, servicing and maintenance are not carried out accurately according to the instructions; repairs are not carried out by our personnel or without our prior written consent.
- Commissioning is not carried out by our personnel or we have not given our approval for the commissioning or the commissioning is carried out by untrained personnel.
- The unit is used inadequately, incorrectly, negligently or inappropriately or for a purpose other than that originally intended.
- The serial number is removed from the product.

For your protection, observe the following safety precautions when setting up your equipment:

- Follow all cautions and instructions marked on the equipment.
- Ensure that the voltage and frequency of your power source match the voltage and frequency inscribed on the equipment's electrical rating label.
- Never push objects of any kind through openings in the equipment. Dangerous voltages may be present. Conductive foreign objects could produce a short circuit that could cause fire, electric shock, or damage to your equipment
- The industrial PC must be mounted on an equipment carrier (1HE) in a 19" rack. A free floating or unilateral mounting may cause defects.
- To ensure the compliance with the EMI and EMC standard, shielded Ethernet and serial cables with the shell grounded at both ends of the cable must be used.

All trademarks or brand marks mentioned in this document are used for identification and are property of their respective owners.

2 Hardware Description

2.1 General

As hardware platform for the gateway a 19" industrial PC is used. This solution offers a high degree of flexibility, performance and reliability. This model is characterized by a very high output and energy efficiency.

Mounting and intensive tests of the industrial PC are done in our company. Before and after a 48 hour burn-in test each device must run through a complete function test.

The housing has an excellent air flow for maximum heat dissipation.

Important for the selection of our components are particular items like quality, availability and a high durability.

The industrial PC consists of a 19" chassis (1U) with two PCIe slots (8 x and 8 x) which enable installation of two PCIe cards.

The mains power supply are 85 – 264 V AC, 104 – 350 V DC auto range, optional 9 – 32 V DC power supply (others on request). The basic system can be extended with corresponding PCIe cards as required.

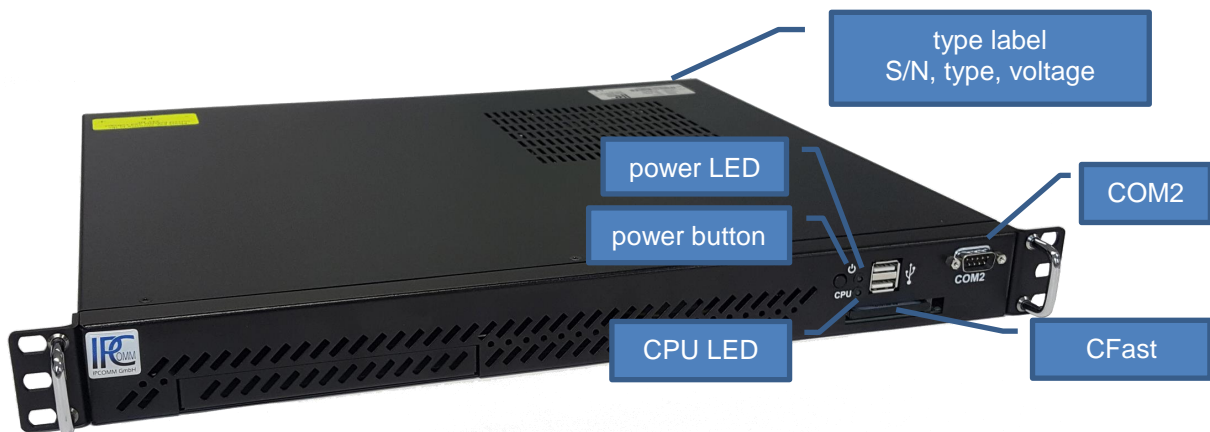

Figure 1: front view IPC1917

Figure 2 shows the reverse side of our Industrial PC. The pin assignments vary according to execution. Overview of the different models can be found in chapter 3 'Overview of Variants / Interface Configuration'.

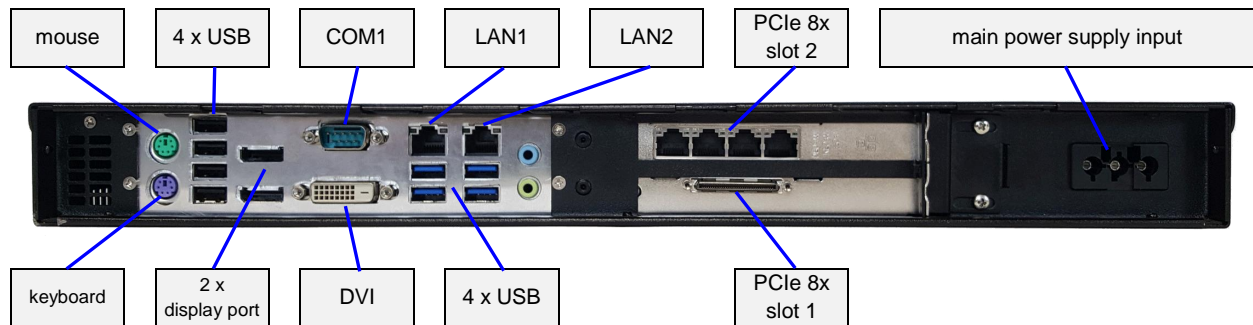

Figure 2: overview interfaces



Figure 3: 8-Port DB9 male connector cable

2.2 Hardware Components

2.2.1 Mainboard

The Mini-ITX mainboard is an ultra-compact x86 platform with two integrated network interfaces and all other necessary interfaces. Its heart consists of a highly energy-efficient Intel i7 processor. The mainboard provides two SODIMM slots for DDR4 memory modules and supports up to 32 GB system memory.

Further interfaces:

- 2 x RS-232
- 4 x SATA
- 2 x LAN 10/100/1000 Mbps BaseT (RJ45)
- DVI
- 2 x display port
- USB
- Two PCIe 8 x

2.2.2 Onboard RS-232 Interfaces

The installed mainboard provides two integrated serial interfaces.

COM1 – COM2

| SERIAL PORT RS-232 DTE DB9 male connector | Pin assignment diagram | | Pin | Direction | Description |
|---|---|--|-----|-----------|-------------------------|
| |  | | | 1 | INPUT |
| | | | 2 | INPUT | RXD Receive Data |
| | | | 3 | OUTPUT | TXD Transmit Data |
| | | | 4 | OUTPUT | DTR Data Terminal Ready |
| | | | 5 | | GND Ground |
| | | | 6 | INPUT | DSR Data Set Ready |
| | | | 7 | OUTPUT | RTS Request To Send |
| | | | 8 | INPUT | CTS Clear To Send |
| | | | 9 | INPUT | RI Ring Indicator |

Figure 4: pin assignment of DB9 9-PIN DTE RS-232 interface (mainboard) COM1-COM2

Note: For the adequate protection against the impact of switching interferences (Burst) and surge voltage, we recommend the use of our 4 kV isolated RS-232 isolator. The used RS-232 transceivers have ESD protection up to 15 kV. The isolator was tested according to EMC guidelines and climatic and mechanical requirements in compliance with the standard IEC 61850-3.

2.2.3 8-Port RS-232 Serial Interface Card (RS-232 interface for remote communication)

Depending on the model each IPC19117 can be equipped with an 8-port or 16-port serial interface card. The following pin assignment is realized with an 8-port DB9 male connector cable (see Figure 3).

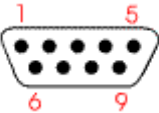
| SERIAL PORT RS-232 DTE DB9 male connector | Pin assignment diagram | | Pin | Direction | Description |
|---|---|--|-----|-----------|-------------------------|
| |  | | | 1 | INPUT |
| | | | 2 | INPUT | RXD Receive Data |
| | | | 3 | OUTPUT | TXD Transmit Data |
| | | | 4 | OUTPUT | DTR Data Terminal Ready |
| | | | 5 | | GND Ground |
| | | | 6 | INPUT | DSR Data Set Ready |
| | | | 7 | OUTPUT | RTS Request To Send |
| | | | 8 | INPUT | CTS Clear To Send |
| | | | 9 | INPUT | RI Ring Indicator |

Figure 5: pin assignment of DB9 interface at serial interface card

See note chapter 2.2.2

2.2.4 Ethernet Interfaces

The industrial PC features three 10/100/1000 Mbps BaseT (RJ45) interfaces. Further interfaces with 10/100 Mbps or 10/100/1000 Mbps BaseT via PCIe are possible on request (up to 10 interfaces per device).

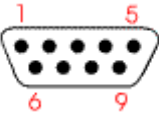
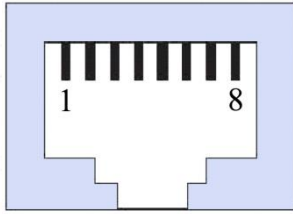

Figure 6: RJ45 network interface

2.2.5 CFast Memory Card

The CFast card serves as a mass storage device, i.e. for storing the operating system, the applications and configuration data. As a result the disadvantages involved with the use of a rotating hard disk are avoided, thus improving the reliability of the system substantially since a CFast has an MTBF of at least 4,000,000 hours.

The CFast adapter is simply connected to the SATA bus of the CPU module and treated just like a hard disk.

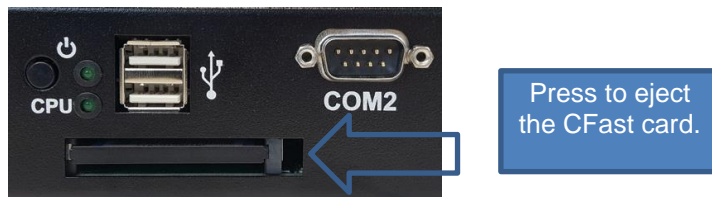

Figure 7: CFast adapter

When the power supply is switched off the CFast card with the entire software can simply be taken out or inserted enabling a quick change to different hardware.

It is possible to install the CFast card inside the device, inaccessible from the outside.

2.2.6 CMOS Lithium Battery

The battery-backed CMOS stores the BIOS system settings. The long-life lithium battery has normally a lifetime of at least six years.

If the CMOS battery is empty and the CMOS information has been deleted, the CMOS-RAM is programmed by the BIOS with default settings.

The converter can be operated faultlessly even if the CMOS RAM is not provided by the battery. After the battery has been changed, only time and date must be input.

Remove six screws on the top to open the housing. The battery holder is soldered in the mainboard and well visible.

Attention! Open-frame power supply units are used. Because of this, the process should be carried out only by experienced electronic engineers. The device must be completely disconnected from any power supply. Before opening please push the power button (without electricity supply) several times to eliminate residual voltages of the power supply.

Battery replacement must be carried out by qualified specialists.

Caution! Incorrect replacement might cause the danger of explosion. Replace the battery exclusively by the same type (**model label: CR-2032**).

The battery should be certified for air transport. Alternatively, it can be ordered directly from us. Used batteries are to be disposed absolutely in accordance with the manufacturer's instructions.

Please pay attention to the correct polarity!

2.2.7 CPU LED

The CPU LED shows the states of conversion software and operating system.

Following figure shows all possible indications:

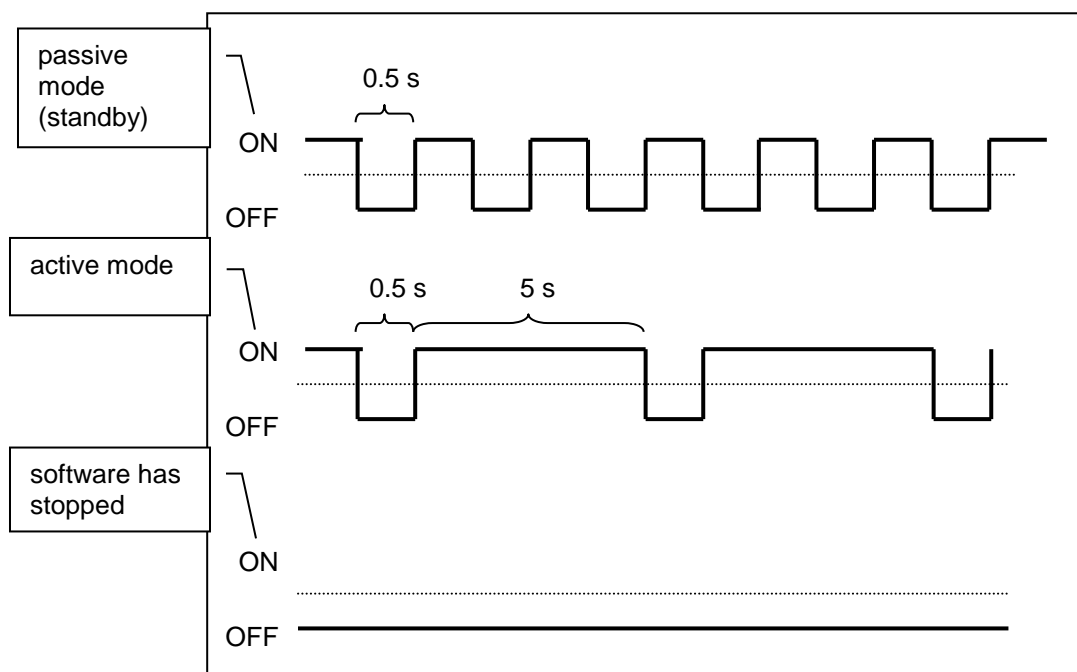

Figure 8: CPU LED indications

2.2.8 Power Supply

Power supplies with different input voltages can be used in the IPC19117. Please pay attention to the correct polarity and input voltage. The input voltage of the respective device is labeled on top of the housing (see Figure 1).

2.2.8.1 AC Power Supply

By using AC voltages a specific power supply cable (see figure below) is supplied. Please use this mapped cable exclusively.



Figure 9: power cable

Note: This device is protected against surge according to the standard IEC 61850-3. When measuring the insulation resistance of devices equipped with surge arresters according to the standard DIN VDE 0701-0702, the test voltage may be reduced to 250 V DC.

2.2.8.2 DC Power Supply

By using DC voltages only a male connector is supplied. This connector has to be used. By connecting the cable with the male connector the correct polarity must be kept. The wire cross-section must be at least 1.5 mm².

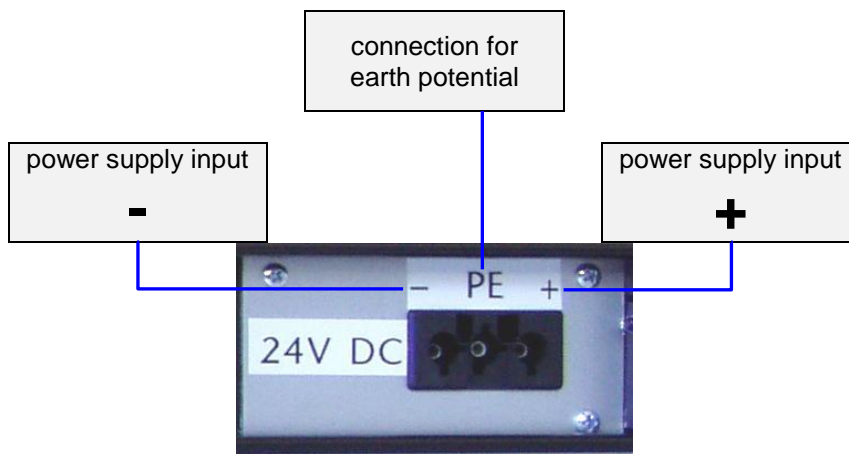

Figure 10: DC voltage connection at power supply

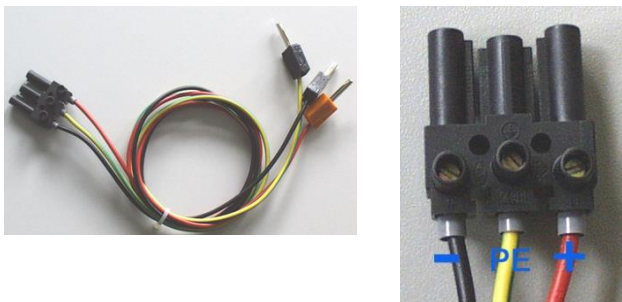

Figure 11: DC power cable (example – not part of the scope of delivery)

3 Overview of Variants / Interface Configuration

The following tables represent the configuration of the individual interfaces of miscellaneous variants. Further variants are available on request.

3.1 Variant A

The device variant A corresponds to the item code HP.I7L.xyz1-0.x .
(See chapter 5 'Nomenclature of IPC19117 Item Code')

| Assembly | Linux Device | I/O Port | IRQ | Label | Connector |
|-----------------|--------------|-----------------------|------|----------------------|-----------|
| mainboard | ttyS0 | 3F8 | 4 | COM1 (chassis rear) | DB9ST |
| | ttyS1 | 2F8 | 3 | COM2 (chassis front) | DB9ST |
| | eth0 | PCIe (onboard) | auto | ETH0 | RJ45 |
| | eth1 | PCIe (onboard) | auto | ETH1 | RJ45 |
| UART adapter 8x | ttyS4 | PCIe 8x (slot bottom) | auto | COM5 | DB9ST |
| | ttyS5 | PCIe 8x (slot bottom) | auto | COM6 | DB9ST |
| | ttyS6 | PCIe 8x (slot bottom) | auto | COM7 | DB9ST |
| | ttyS7 | PCIe 8x (slot bottom) | auto | COM8 | DB9ST |
| | ttyS8 | PCIe 8x (slot bottom) | auto | COM9 | DB9ST |
| | ttyS9 | PCIe 8x (slot bottom) | auto | COM10 | DB9ST |
| | ttyS10 | PCIe 8x (slot bottom) | auto | COM11 | DB9ST |
| | ttyS11 | PCIe 8x (slot bottom) | auto | COM12 | DB9ST |

3.2 Variant E4M

The device variant E4M corresponds to the item code HP.I7L.xyz1-2.x .
(See chapter 5 'Nomenclature of IPC19117 Item Code')

| Assembly | Linux Device | I/O Port | IRQ | Label | Connector |
|---------------------|--------------|-----------------------|------|----------------------|-----------|
| mainboard | ttyS0 | 3F8 | 4 | COM1 (chassis rear) | DB9ST |
| | ttyS1 | 2F8 | 3 | COM2 (chassis front) | DB9ST |
| | eth0 | PCIe (onboard) | auto | ETH0 | RJ45 |
| | eth1 | PCIe (onboard) | auto | ETH1 | RJ45 |
| Ethernet adapter 4x | eth2 | PCIe 8x (slot top) | auto | ETH2 | RJ45 |
| | eth3 | PCIe 8x (slot top) | auto | ETH3 | RJ45 |
| | eth4 | PCIe 8x (slot top) | auto | ETH4 | RJ45 |
| | eth5 | PCIe 8x (slot top) | auto | ETH5 | RJ45 |
| UART adapter 8x | ttyS4 | PCIe 8x (slot bottom) | auto | COM5 | DB9ST |
| | ttyS5 | PCIe 8x (slot bottom) | auto | COM6 | DB9ST |
| | ttyS6 | PCIe 8x (slot bottom) | auto | COM7 | DB9ST |
| | ttyS7 | PCIe 8x (slot bottom) | auto | COM8 | DB9ST |
| | ttyS8 | PCIe 8x (slot bottom) | auto | COM9 | DB9ST |
| | ttyS9 | PCIe 8x (slot bottom) | auto | COM10 | DB9ST |
| | ttyS10 | PCIe 8x (slot bottom) | auto | COM11 | DB9ST |
| | ttyS11 | PCIe 8x (slot bottom) | auto | COM12 | DB9ST |

3.3 Variant E4

The device variant E4 corresponds to the item code HP.I7L.xyz0-2.x .
(See chapter 5 'Nomenclature of IPC19117 Item Code')

| Assembly | Linux Device | I/O Port | IRQ | Label | Connector |
|---------------------|--------------|--------------------|------|----------------------|-----------|
| mainboard | ttyS0 | 3F8 | 4 | COM1 (chassis rear) | DB9ST |
| | ttyS1 | 2F8 | 3 | COM2 (chassis front) | DB9ST |
| | eth0 | PCIe (onboard) | auto | ETH0 | RJ45 |
| | eth1 | PCIe (onboard) | auto | ETH1 | RJ45 |
| Ethernet adapter 4x | eth2 | PCIe 8x (slot top) | auto | ETH2 | RJ45 |
| | eth3 | PCIe 8x (slot top) | auto | ETH3 | RJ45 |
| | eth4 | PCIe 8x (slot top) | auto | ETH4 | RJ45 |
| | eth5 | PCIe 8x (slot top) | auto | ETH5 | RJ45 |

3.4 Variant E8

The device variant E8 corresponds to the item code HP.I7L.xyz2-2.x .
(See chapter 5 'Nomenclature of IPC19117 Item Code')

| Assembly | Linux Device | I/O Port | IRQ | Label | Connector |
|---------------------|--------------|-----------------------|------|----------------------|-----------|
| mainboard | ttyS0 | 3F8 | 4 | COM1 (chassis rear) | DB9ST |
| | ttyS1 | 2F8 | 3 | COM2 (chassis front) | DB9ST |
| | eth0 | PCIe (onboard) | auto | ETH0 | RJ45 |
| | eth1 | PCIe (onboard) | auto | ETH1 | RJ45 |
| Ethernet adapter 4x | eth2 | PCIe 8x (slot top) | auto | ETH2 | RJ45 |
| | eth3 | PCIe 8x (slot top) | auto | ETH3 | RJ45 |
| | eth4 | PCIe 8x (slot top) | auto | ETH4 | RJ45 |
| | eth5 | PCIe 8x (slot top) | auto | ETH5 | RJ45 |
| Ethernet adapter 4x | eth6 | PCIe 8x (slot bottom) | auto | ETH6 | RJ45 |
| | eth7 | PCIe 8x (slot bottom) | auto | ETH7 | RJ45 |
| | eth8 | PCIe 8x (slot bottom) | auto | ETH8 | RJ45 |
| | eth9 | PCIe 8x (slot bottom) | auto | ETH9 | RJ45 |

3.5 Variant L

The device variant L corresponds to the item code HP.I7L.xyz0-0.x .
(See chapter 5 'Nomenclature of IPC19117 Item Code')

| Assembly | Linux Device | I/O Port | IRQ | Label | Connector |
|-----------|--------------|----------------|------|----------------------|-----------|
| mainboard | ttyS0 | 3F8 | 4 | COM1 (chassis rear) | DB9ST |
| | ttyS1 | 2F8 | 3 | COM2 (chassis front) | DB9ST |
| | eth0 | PCIe (onboard) | auto | ETH0 | RJ45 |
| | eth1 | PCIe (onboard) | auto | ETH1 | RJ45 |

4 Technical Data

Chassis

- 19" rack mount chassis (1U)
- Dual PCIe riser card
- Excellent air flow for maximum heat dissipation with ball bearing mounted industrial fans

Power Supply AC

- Fanless
- 85 – 264 V AC, 104 – 350 V DC auto range
- Input frequency: 47 – 63 Hz
- Hold up time: > 40 ms at 230 V AC and full load, 10 ms at 115 V AC and full load
- Switch-on delay: 300 - 500 ms
- Power consumption: max. 100 W (depending on the used type)
- CE, UL 60950-1, EN 60950-1, IEC 61850-3

Power Supply DC (optional)

- Fanless
- 9 – 32 V DC
- Hold up time: > 50 ms
- Switch-on delay: 100...500 ms
- Power consumption: max. 70 W (depending on the used type)
- CE, UL 60950-1, EN 60950-1, IEC 61850-3

Mainboard / CPU

- Intel Core i7 Quad-Core CPU 3,4 GHz with Hyper-Threading Technology
- DDR4 RAM max. 32 GB
- SATA interfaces
- 2 serial interfaces outward
- 2 x RJ45 10/100/1000 BaseT LAN interfaces onboard
- 6 x USB 2.0 outward
- 4 x USB 3.0 outward
- RAID SATA functionality (RAID Level 0/1)

Serial Cards

- Up to 32 RS-232 interfaces
- DB9 male connector
- Baud rate 300 bps to 921,600 bps
- 15 KV ESD protection

Diagnostics

- Power LED
- LED to show different software conditions

Additional Functions

- Battery buffered real-time clock (RTC)
- Reset

Mass Storage CFast

- Rugged CFast card, industrial – grade
- Max. 64 GB capacity
- MTBF \geq 4,000,000 hours
- No moving parts
- Removable flash card
- Bad Block Scanning/Handling
- Static Wear-Leveling System
- ECC
- Very short access time

Mass Storage SATA HDD Raid Level 1 or 0 possible (optional)

- Two server HDD for continuous operation
- Max. 2 TB
- MTBF \geq 1,200,000 hours

Mass Storage SATA SSD, Raid Level 1 or 0 possible (optional)

- No moving parts
- Max. 128 GB
- Very short access time
- Very high write/read performance

Supported Operating Systems

- Linux

Optical Drive (optional)

- CD/DVD writer with slot-in technology

Video

- 1 x DVI interface, 2 x display port

Operating Environment

- Operating temperature: 0 °C to 45 °C
- Storage temperature: 0 °C to 60 °C
- Relative humidity: 5 % to 95 % not condensing

General

- Height: 1 U
- Dimension (W x H x D): 19" x 1.75" x 15" (482.6 mm x 44.45 mm x 381 mm)
- Weight: approx. 6 kg (depending on the used type)

Standards

IEC 61850-3:2013*)
IEC 61000-6-2:2005
IEC 61000-6-4:2006 + A1:2010
CISPR 22:2008

Electromagnetic Compatibility (EMC) - Emissions

Conducted and Radiated Emissions: IEC 61000-6-4
CISPR 22:2008
Voltage Flicker: IEC 61000-3-3:2013
Harmonic Current: 61000-3-2:2014

Electromagnetic Compatibility (EMC) - Immunity

Fast Transient/Burst: IEC 61000-4-4:2012
Severity Level: Class A
4 kV on power supply and outputs;
1 kV, 4 kV on communications lines

Surge Immunity: IEC 61000-4-5:2014
AC Power Supply: 4 kV line <-> ground
2 kV line <-> line
DC Power Supply: 2 kV line <-> ground
1 kV line <-> line

Conducted RF: IEC 61000-4-6:2014
Severity Level: 10 Vrms

Power Supply: IEC 61000-4-11
IEC 61000-4-17
IEC 61000-4-29

Electrostatic Discharge: IEC 61000-4-2
2, 4, 6 kV contact discharge;
2, 4, 8 kV air discharge

Radiated Radio Frequency: IEC 61000-4-3:2006 + A1:2007 + A2:2010
Severity Level: 10 V/m

Immunity to damped oscillatory waves: IEC 61000-4-18:2006+A1:2010
Power supply and outputs
Severity Level: 2.5 kV peak common mode
1.0 kV peak differential mode

*) except serial, USB and Ethernet interfaces
(If required, corresponding interfaces must be externally protected e.g., by using our RS-232 Isolator.)

(The test report is available on request.)

Assembled by IPCOMM GmbH/Germany

5 Nomenclature of IPC19117 Item Code

The IPC19117 item code gives information about the gateway configuration.

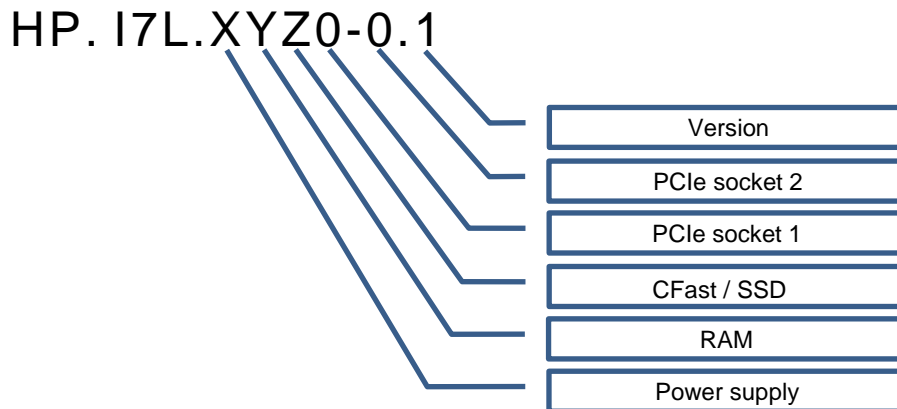

Power supply

| Value | Description |
|-------|---------------|
| A | 85 – 264 V AC |
| B | 24V DC |

RAM

| Value | Description |
|-------|-------------|
| I | 8 GB |
| J | 16 GB |
| S | 32 GB |

CFast¹⁾

| Value | Description |
|-------|-------------|
| F | 4 GB |
| H | 16 GB |
| I | 32 GB |
| J | 64 GB |

SSD¹⁾

| Value | Description |
|-------|-------------|
| S4 | 120 GB |
| S5 | 150 GB |

PCI express sockets 1/2

| Value | Description |
|-------|----------------------------|
| 0 | Not equipped |
| 1 | 8-port RS232 PCIe adapter |
| 2 | Ethernet adapter 4-port |
| 9 | 16-port RS232 PCIe adapter |

¹⁾ combinations of CF and SSD are hyphenated e.g., F-S4 (CF = 4 GB, SSD = 120 GB)

6 IPC191 CAD-Chart

